



MESSER 
Cutting Systems

PROBLADE
SOLID DESIGN – HIGH QUALITY

PROBLADE

SOLID DESIGN – HIGH QUALITY AT A VALUE FOR MONEY PRICE



The modern cnc control Global Control and the plasma interface are mounted where the operator can easily see and adjust them.



The optional high frequency punch marker permits accurate marking of points and lines.



The track is quickly and easily installed.



Multiple ALFA torches with quick change permit high production.





th quick nozzle
ctivity.

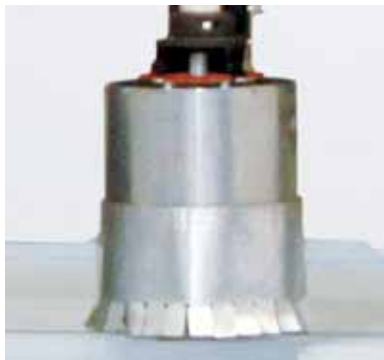

The plasma torch has a sight screen and
automatic collision protection.



PROBLADE THE BENEFITS

- Messer quality at a reasonable price
- Value for money
- 18 m/min speed means less positioning time so more output
- Short lifts between cuts gives higher productivity
- Low installation costs through fast installation
- Stable track construction maintains accuracy, not easily misaligned
- Direct drive for reduced backlash and better power transmission
- Ergonomic design
- Can take up to 4 torches (max. 3 oxyfuel and 1 plasma) giving higher productivity
- Tough enough for a hard day's work
- Up to 3 m (10') plate width allows cutting of large parts and efficient nesting of smaller ones to reduce scrap
- User-friendly touch screen control
- Twinside longitudinal rack and pinion drive for accurate, reliable performance
- Can cut up to 150 mm (6") with one torch 75 mm (3") with all 4 so it is able to handle the heavy jobs
- OmniWin Standard Edition for efficient offline nesting including voucher for upgrade

And many more...

PROBLADE

Technical Data (values in mm)

A Track Gauge	3100	3600	4000
B Working Width	2000	2500	3000
C Overall Width	4410	5310	5310
D Length	1330	1330	1330
E Height	2100	2100	2100
F Track Height	565	565	565

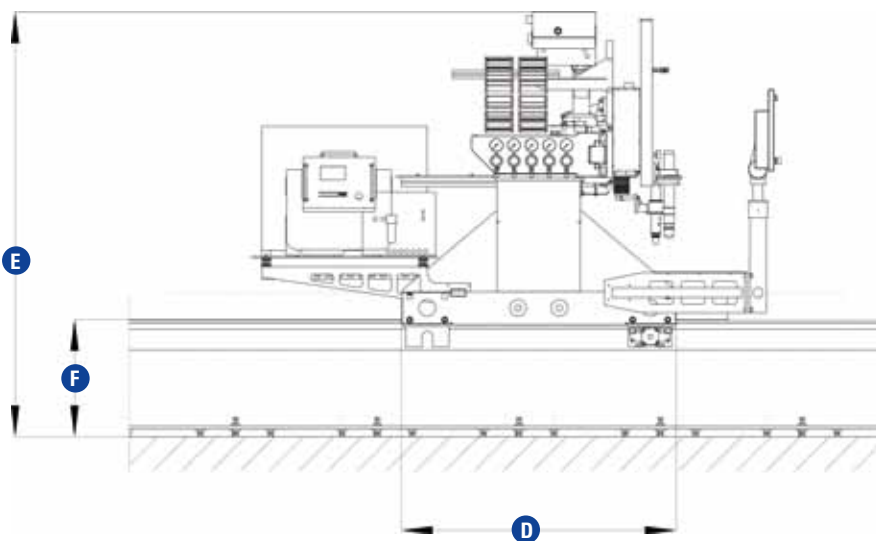
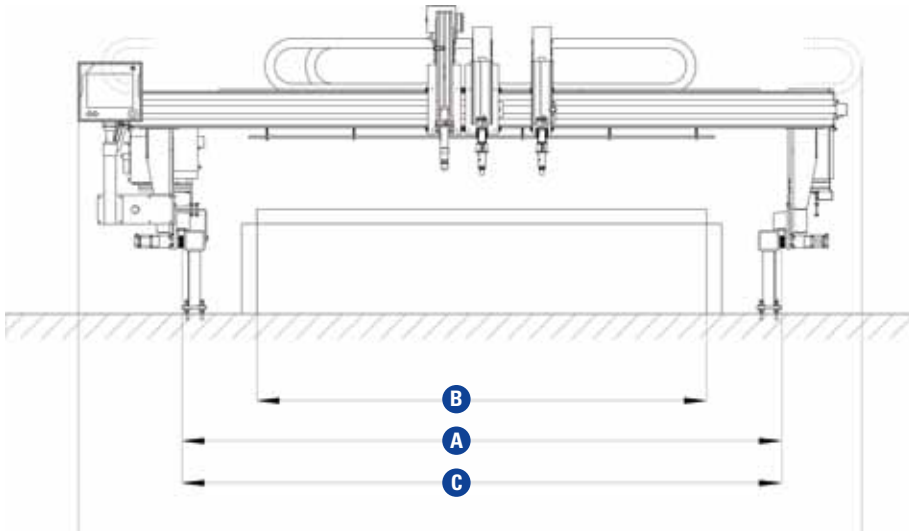

Messer Cutting Systems GmbH
 Otto-Hahn-Straße 2-4
 64823 Groß-Umstadt
 Germany
 Tel. +49 (0) 6078 787-0
 Fax +49 (0) 6078 787-150
 info@messer-cs.de
 www.messer-cs.de
 www.problade.info